

# LTX-50



## DEVICE

## 50 GHz Lightwave Transmitter Module for RFoF

## OVERVIEW

The Optilab LTX-50 is a high performance Lightwave Transmitter Module designed for analog photonics applications from 10 MHz to 50 GHz. This unit includes a 50 GHz optical intensity modulator and an Automatic Bias Control (ABC) board with four different operating modes. The integrated Tunable Wavelength Laser makes it a versatile solution for RFoF system integration. The LTX-50 requires a single 12 Volt DC power supply for operation. Contact Optilab for more information.

## FEATURES

- 31 GHz S21 bandwidth modulator
- 1527 nm to 1567 nm LD wavelength range
- Automatic Bias Control w/ 4 mode operation
- Internal TWL laser up to 40 mW
- Single 12V power supply required (not included)
- Customizable Options:
  - Low Drive Voltage
  - PM Output
  - High Extinction Ratio (>30 dB)

## USE IN

- Analog photonics
- 43 GHz RFoF transmission
- RF/IF signal distribution
- Satellite communication
- Optical communications to 50 Gb/s
- Picosecond pulse generation

## FUNCTIONAL DIAGRAM

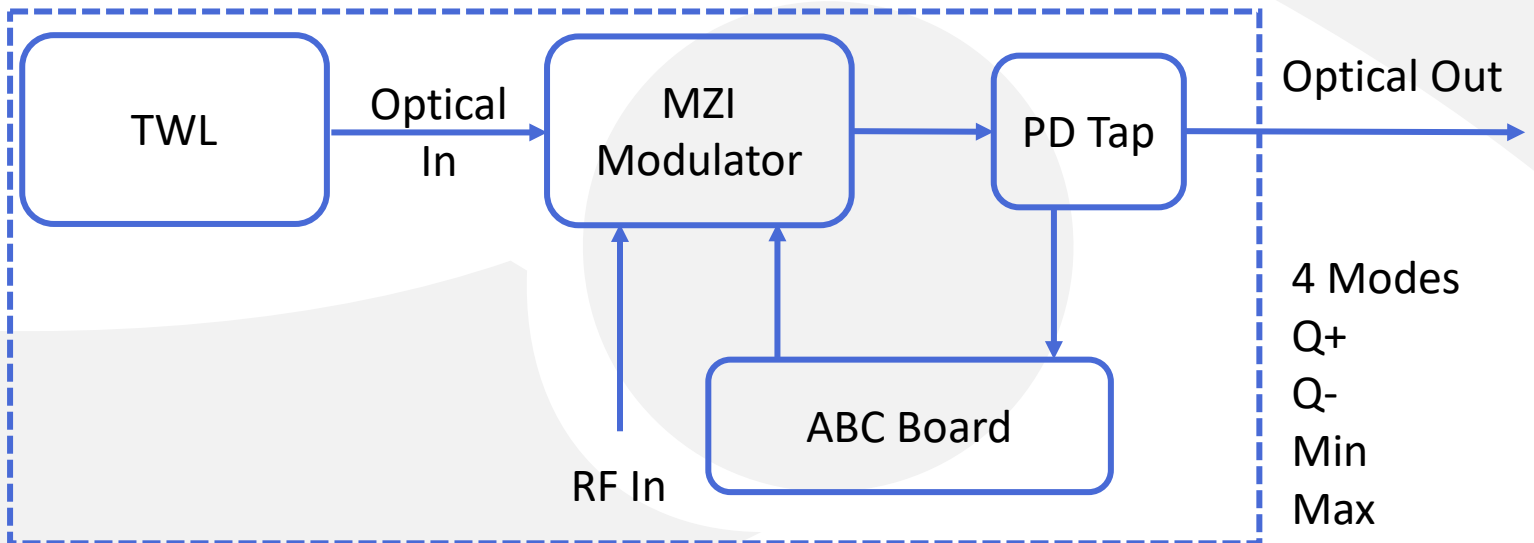

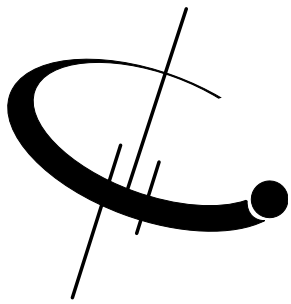

# LTX-50

## SPECIFICATIONS

Modulator Operating Wavelength	1520 nm to 1610 nm
Laser Source	Tunable Wavelength Laser, 1526 nm to 1567nm
Laser Power Level	Up to 40mW
RF Return Loss	≤ -10 dB @ 20 GHz
Impedance	50Ω
Operating Frequency Range	10 MHz to 50 GHz
Input RF Voltage	27 dBm max.
Optical Output Level	6.5 dBm typ. With 20 mW DFB
S21 Bandwidth	31 GHz typ. @ -3 dB, 55 GHz typ. @ -6 dB
Modulator Bias Mode	4 Automatic bias control modes, selectable by software
Extinction Ratio	25 dB typ.; > 30 dB (HE version)
Modulator Voltage $V_{PI}$	3 V typ. @ 10 GHz typ

## GENERAL

Operating Temperature (standard)	-30°C to +60°C
Storage Temperature	-60°C to +90°C
Power Supply Requirements	+ 12 V DC, 1 A typ.
Optical Connectors	FC/APC
Fiber Type	SMF-28 output, PANDA output (PM version)
RF Input Connector	2.4mm connector
Power Connector	DB-15
Remote Control	RS-232, DB-15
Alarm	LED bias mode status
Dimensions	220mm x 119mm x 27mm

## MECHANICAL

## ANALOG LINK PERFORMANCE

IIP3 @ 7 GHz	29 dBm typ.; 25 dBm typ. (LD version)
1 dB Compression Point @ 10 GHz	16 dBm typ.; 8 dBm typ. (LD version)

## BIAS CONTROL MODE

Q+	Set to quadrature point of positive slope for linear analog modulation
Q-	Set to quadrature point of negative slope for linear analog modulation
Min	Set to min. point of operation for pulse generation of digital modulation
Max	Set to max. point of operation for pulse generation of digital modulation



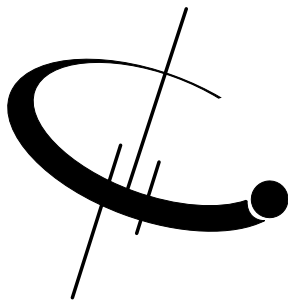

# LTX-50

## TYPICAL S21 AND S11 BANDWIDTH

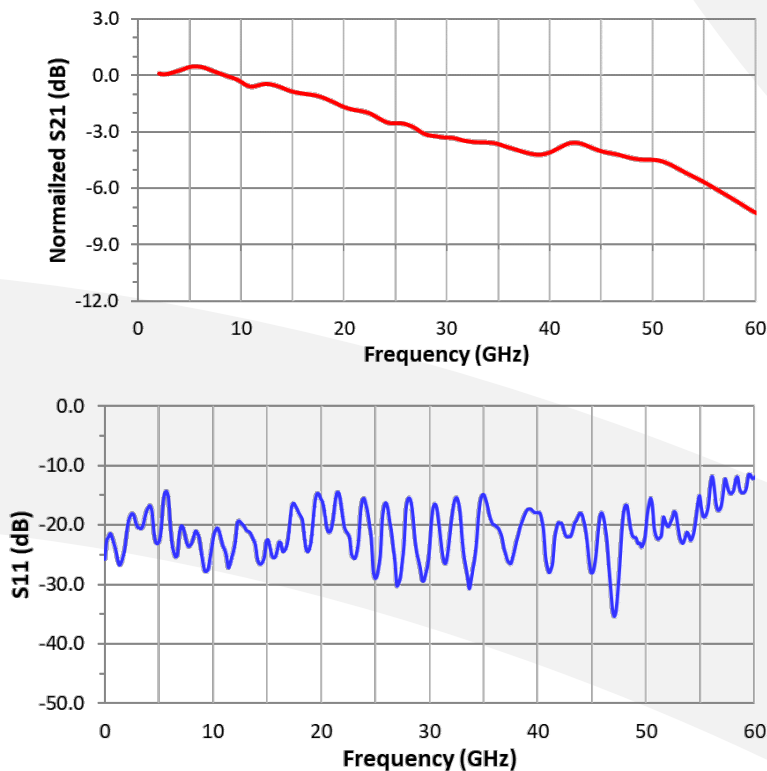

## BIAS SETTING MODES FOR LTX

Based on sophisticated phase measurement of this small dither signal, LTX-50 provides four selectable operating modes: quadrature (Quad +), inverted quadrature (Quad -), minimum (Min), or maximum (Max) points.

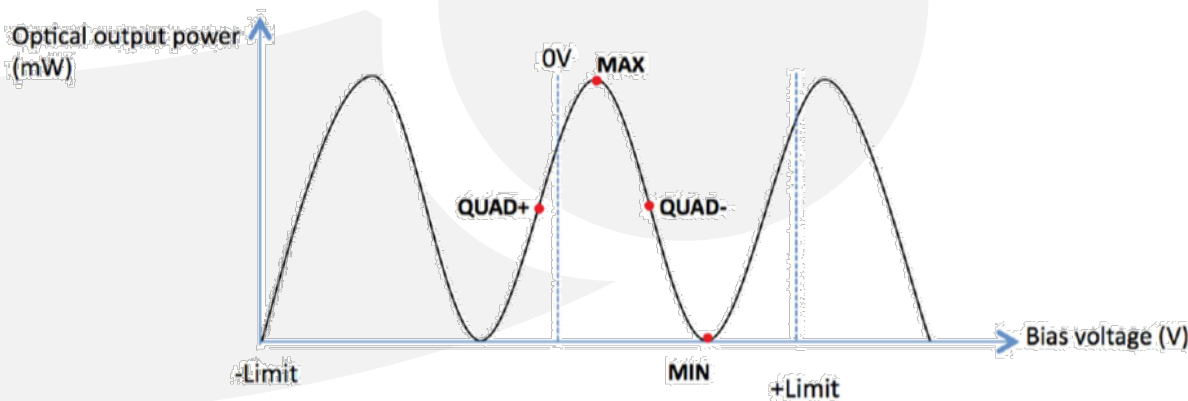

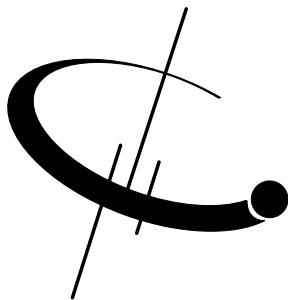

# LTX-50

## MECHANICAL DRAWING

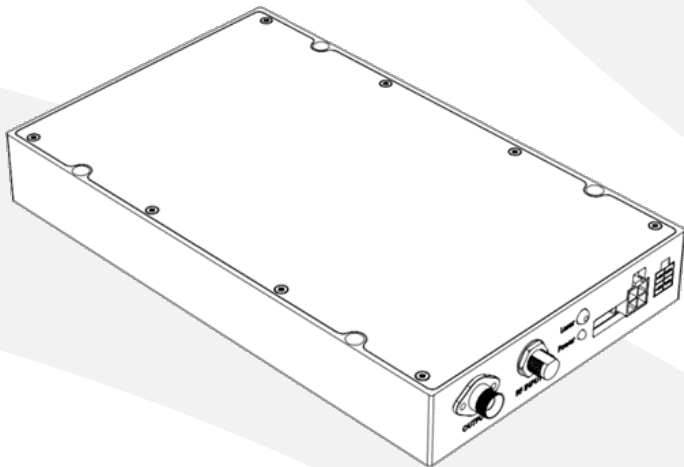
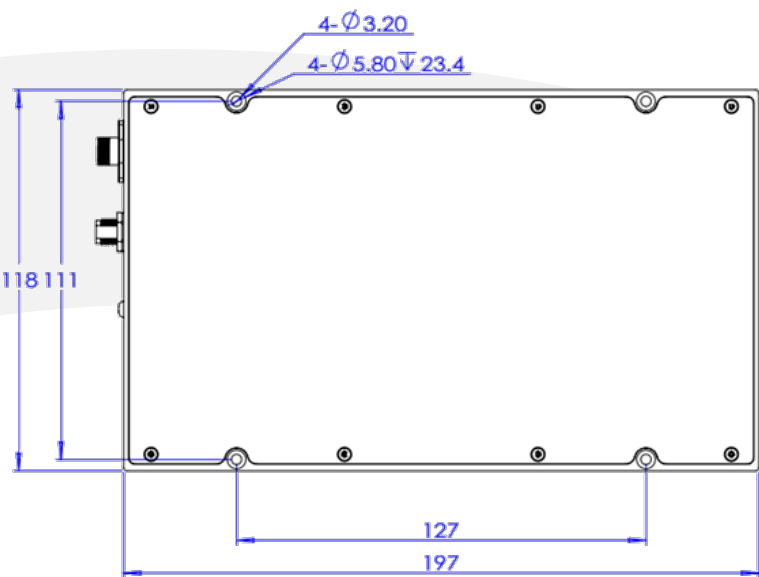
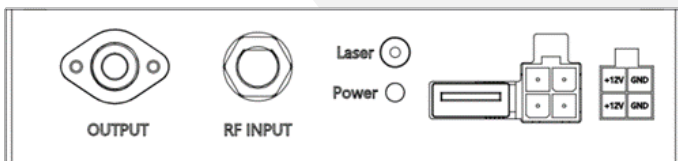
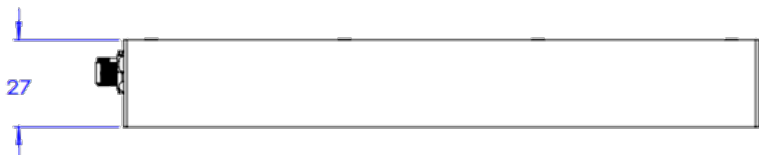

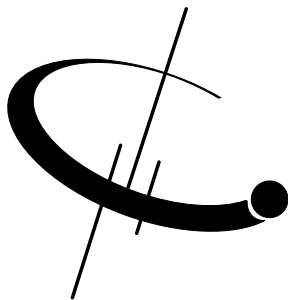

# LTX-50

PRECISION POWER SUPPLY FOR LTX (OPTIONAL)

FRONT



BACK

