



# Spectral Analysis of Lasers; SuperCavity Optical Spectrum Analyzer Alignment Instructions and Demonstration

Newport

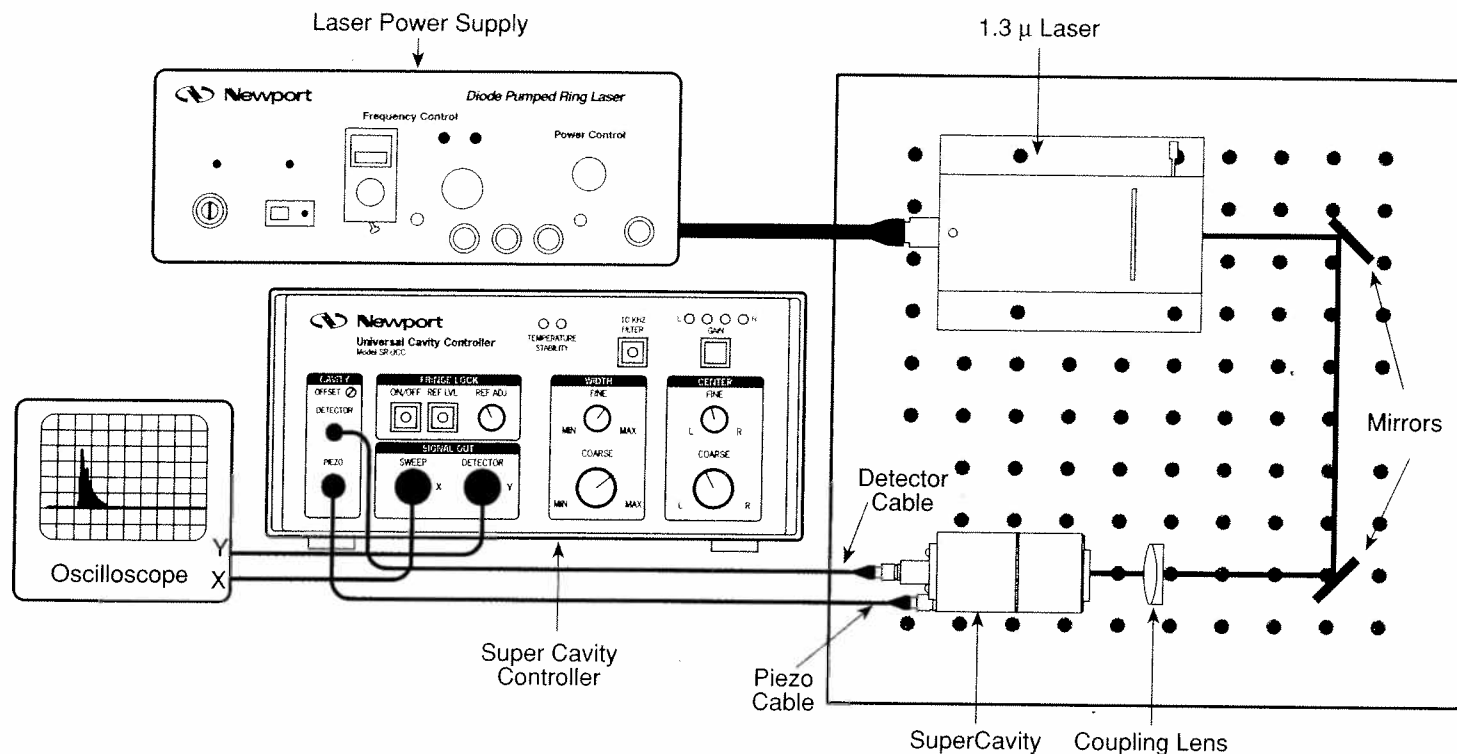

Fig. 1. – Setup and wiring diagram for SuperCavity System.

## Summary:

The following is a description of a setup that demonstrates the Newport SuperCavity Optical Spectrum Analyzer. This is also a demonstration of the alignment and mode matching typically encountered with non-confocal optical resonant cavities. Included are step-by-step alignment instructions for Model 260 SuperCavity using a 1.3 micron Nd:YAG laser. A schematic of the setup is shown in Fig. 1. The user needs to furnish an x-y scope.

## List of Equipment:

1. SuperCavity system, Model SR-260, with a Certification of Performance. The SuperCavity has the following specs:
 

Finesse .....	6000
Efficiency .....	65%
Free Spectral Range .....	7500 GHz
Wavelength .....	1320 nm
2. SuperCavity controller, Model SR-UCC, with two cables, one for the detector and one for the piezo.
3. Diode pumped Nd:YAG ring laser which contains a laser head, power supply driver and manual. This laser is a narrow linewidth single-mode laser operating at 1.3 microns. Output power is about 30 mW. The laser head contains a 30dB optical isolator.
4. Two mirror mounts and two IR enhanced mirrors. Two extra mirrors are also included.
5. Lens mount and a 38mm focal length achromat lens. An extra lens is also included.

6. IR sensor card, card holder and a strip of IR sensor card, a hand-held IR viewer and protective safety eye glasses for 1300nm radiation.
7. 1' x 1' breadboard.
8. Two instruction manuals, one for SuperCavity and the other for the Fiber Input Adapter.

## WARNING

**The high power laser generates 30 to 35 mW of power at 1.32 microns. Eye protection must be worn at all times to eliminate the possibility of eye injury due to stray or scattered light entering the eye.**

## ALIGNMENT PROCEDURE:

Figures 1 through 13 will be used to setup the equipment and to complete the alignment of SuperCavity.

1. Initial connections and warm up: SuperCavity may require 15 minutes to warm up. Hence, it is suggested to turn it ON before alignment is started. Insert the SuperCavity into its mount (the LP-1). Install the cables between the SuperCavity and the controller and turn the SR-UCC controller ON. It takes about 15 minutes for the thermal servo to stabilize. In 15 minutes the green **TEMPERATURE STABILITY** light on the controller should turn ON and stay ON. If it does not stay ON then refer to the SuperCavity instruction manual for trouble shooting or call your local Newport representative.

- Mirrors: Install the mirrors and mirror mounts (MM2) in their location as shown in Fig. 2. Do not install the LP-1 onto the breadboard at this time.

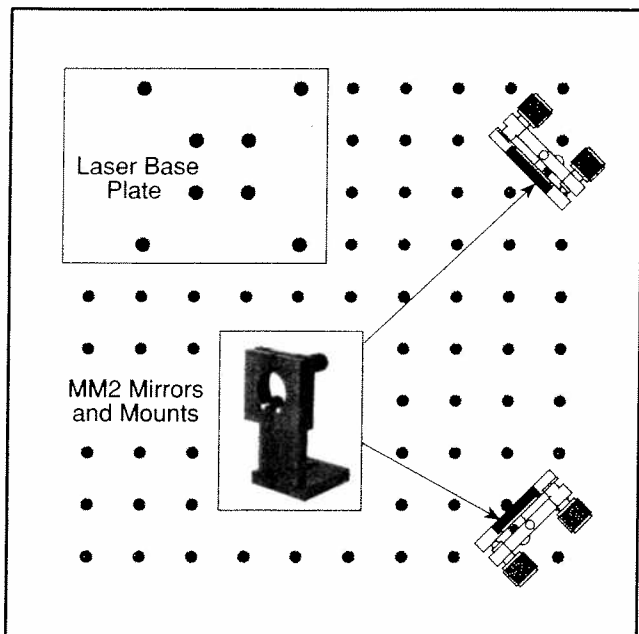

Fig. 2. – Install the mirrors and mounts MM2.

- Laser: Install the Nd:YAG laser on the breadboard as shown in Fig. 3.

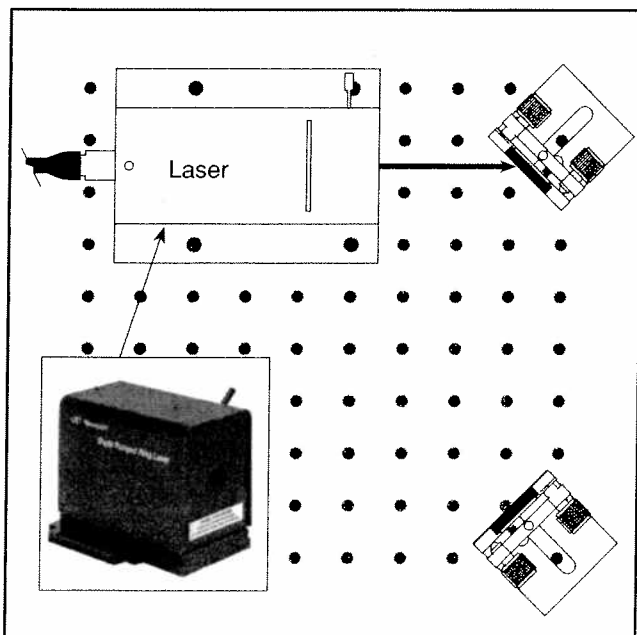

Fig. 3. – Laser installation. Note that the power connector is keyed. To install the connector, align the red dot to the red mark on the mating receptacle. To release the connector gently pull on the knurled section. The connector will release.

- Laser interconnections: Plug the power cords in for the laser. Turn Power Control knob (Fig. 4) fully clockwise, to get maximum power (30 to 35 mW) and turn ON/OFF key to ON. Wait 20 seconds. System status LED should be ON. Press the Attenuate button (toggle switch) firmly to turn output laser power ON/OFF. The Attenuate LED is ON to indicate laser power is ON. Refer to the instruction manual for proper operating procedure for the laser. Use the IR sensor card to sense the beam.

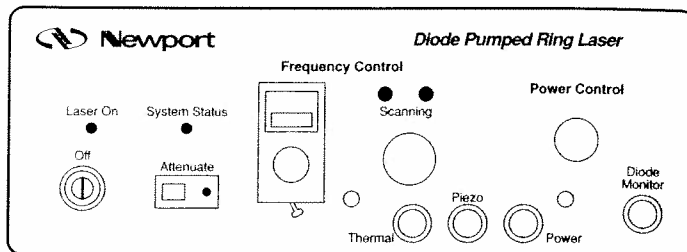

Fig. 4. – Laser interconnections.

- Beam alignment: This step is to ensure coarse alignment of the input beam with respect to the SuperCavity. Align the input beam from the laser so it is reflected off the two unmasked areas on the two mirrors, as shown in Fig. 5. Use the little strip of sensor card to locate the beam.

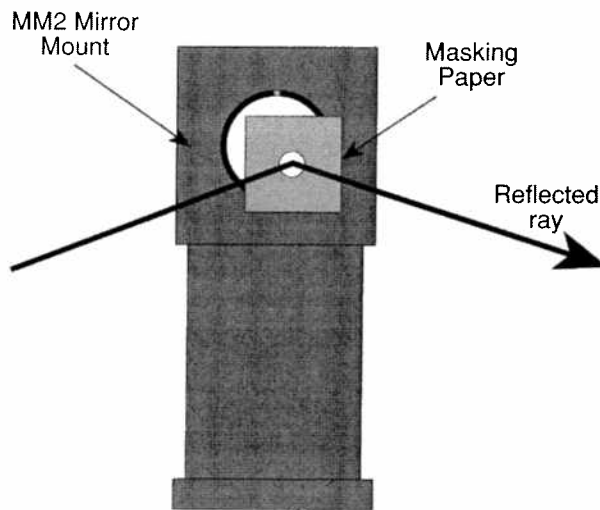

Fig. 5. – Beam alignment.

- Coarse alignment of beam: Complete the alignment shown in Fig.5. Check the beam propagation after reflecting off the second mirror. It should be traveling roughly parallel to the edge of the breadboard and to the horizontal plane. Adjust the two mirrors as necessary to correct the alignment of the ray.

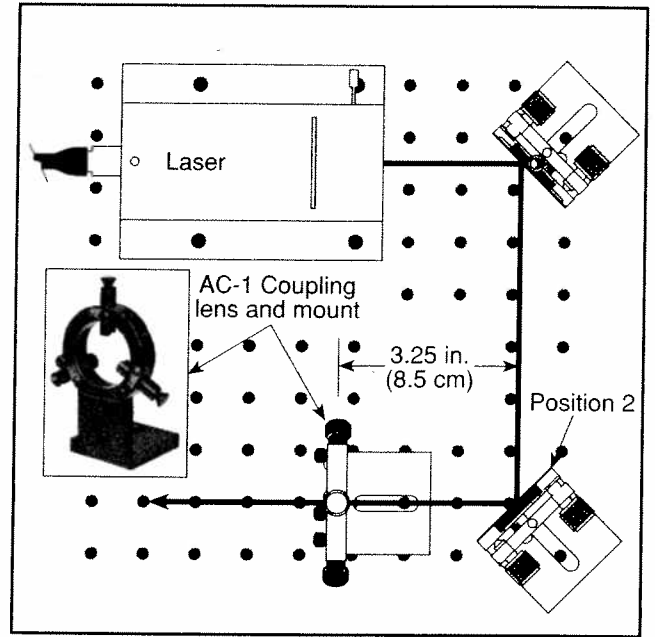
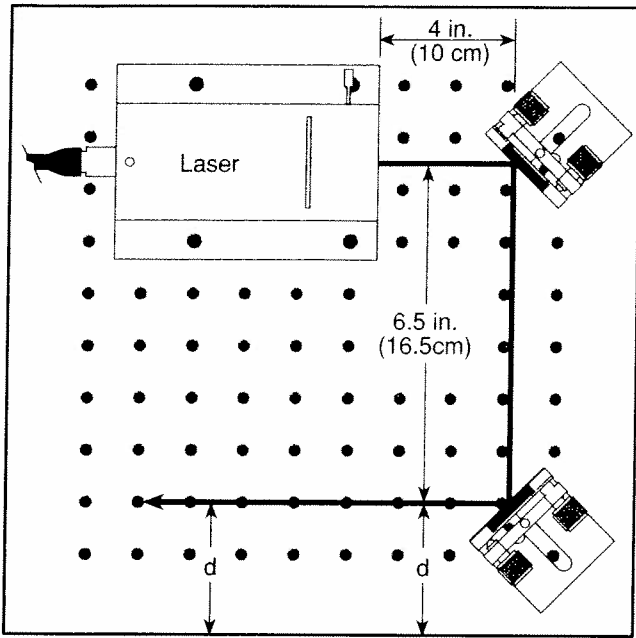

Fig. 7. – Install coupling lens and mount.

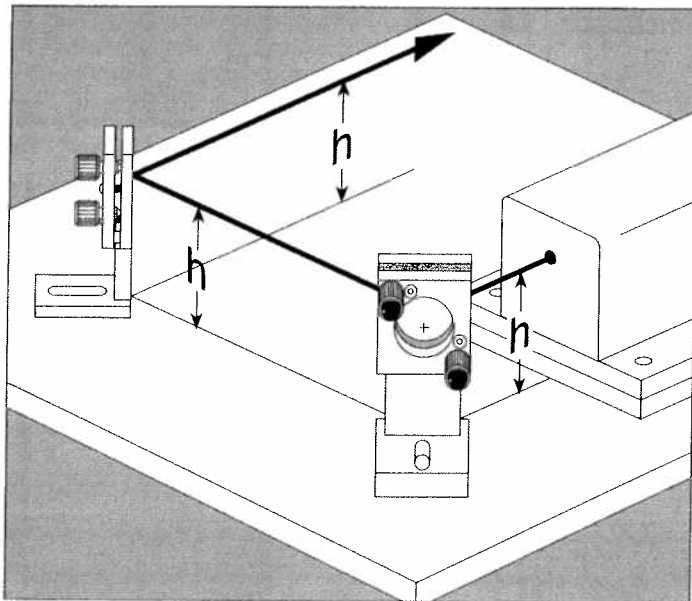

Fig. 6. – Coarse alignment of beam. The laser beam should be travelling roughly parallel to the edge of the breadboard and the horizontal plane.

7. Coupling lens and mount: install the lens and lens mount assembly in the indicated area, as shown in Fig. 7. Note that the input beam is located near the center of the coupling lens. Adjust the second mirror mount (MM2) if it is not. The coupling lens is of focal length = 38mm and diameter = either 0.5 or 1.0 in. The lens should be positioned approximately 3.25 inches from the second MM2 mirror.

8. SuperCavity: Install the SuperCavity and the LP-1 mount onto the breadboard, as shown in Fig. 8. Adjust the z axis lever on the LP-1 mount to the midway position. Attach BNC cables from the SR-UCC controller to your X-Y scope.

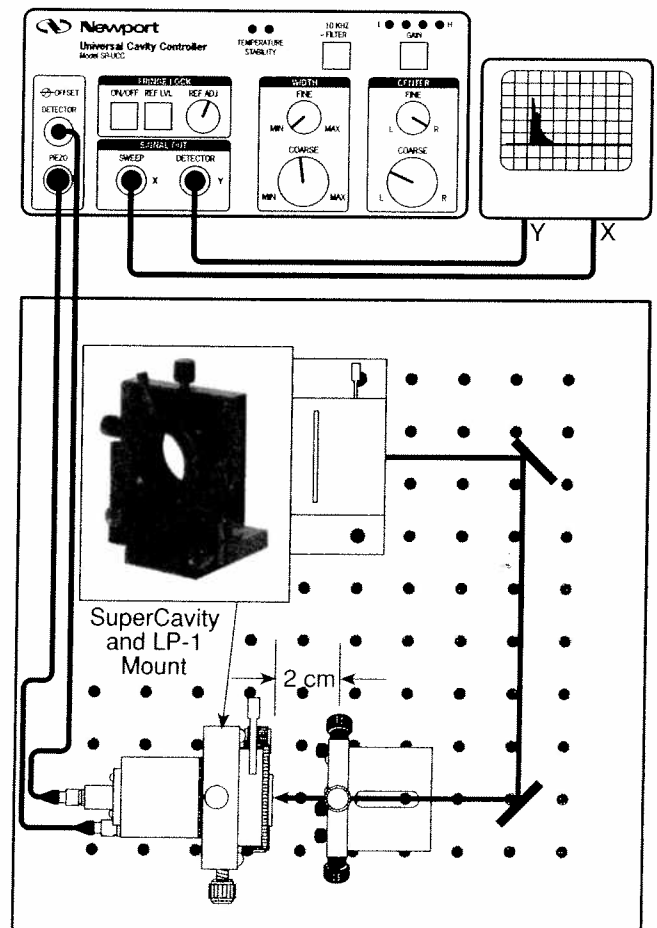

Fig. 8. – Install SuperCavity and LP-1 mount.

9. Lens location: Mount orientation should be such that the lens is roughly 2 cm away from the front face of SuperCavity. Adjust the z axis control lever on the LP-1 mount to control the SuperCavity axial position.
10. Lens focal length: The choice of focal length of the coupling lens is done as follows; measure roughly the spot size at the lens location. It is 1 to 1.5mm dia. The manual suggests a focal length of 32 to 48mm. We chose a 38 mm focal length doublet lens. The choice of an achromat slightly improves the coupling efficiency by decreasing the aberrations in the beam. For further information on "Mode Matching To SuperCavity" please refer to section 2.1.4 in the SuperCavity instruction manual.
11. Angular alignment of SuperCavity: This is an important alignment step. It ensures that the input beam is aligned parallel to the optic axis of the cavity (it might help to dim the lab lights while completing the alignment).

Translate the SuperCavity in the x and y direction by adjusting the x and y control knobs on the LP-1 mount such that the input beam is focused at the front alignment mirror of SuperCavity (shown in Fig. 9).

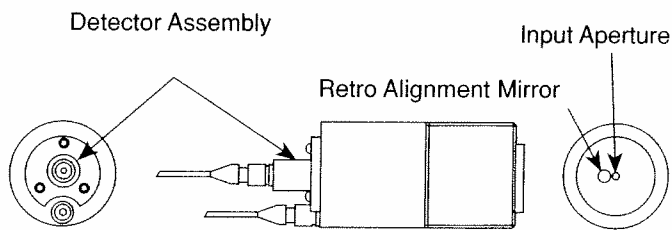

Fig. 9 – Location of the front alignment mirror and the input aperture of SuperCavity.

Use the provided IR card, card holder and the small strips of IR sensor card to locate the beam. A small hole (about 1 mm dia) may be made in the card and used as a pinhole

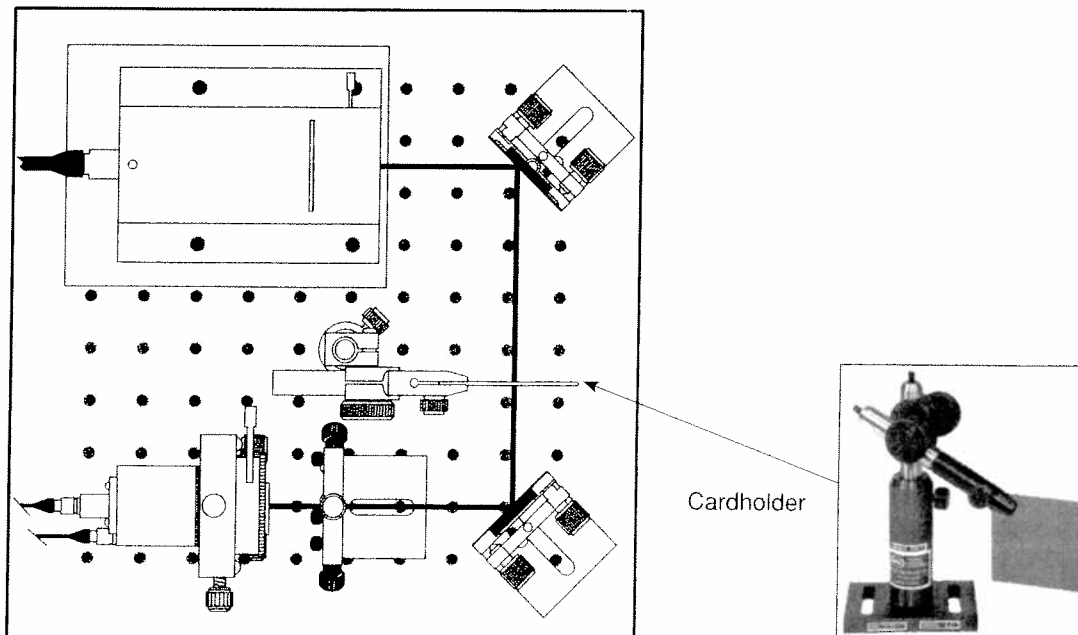

Fig. 10. – IR sensor card and pinhole positioning

for alignment. Place the pinhole in the beam path, as shown in Fig. 10.

Adjust the angle controls on the LP-1 such that the reflected beam is coincident with the input beam. Verify this at the aperture plane and also at the first mirror position. Note that following two observations: the mechanical axis of SuperCavity should be approximately aligned with the input beam, and that the reflected beam is larger than the incident beam because of the positions of the lens and the mirror..

12. Front aperture for SuperCavity: Use a small strip of IR sensor card to locate the beam at the input face of SuperCavity. Using the x and y axis controls on the LP-1 mount, translate the SuperCavity such that the focused beam enters the input aperture at the center of the front face of SuperCavity.
13. Equipment settings: Turn scope ON, set gain to 0.5 V/div. Set the gain on controller to maximum, and set the filter to OUT position (LED off). Set the width coarse knob to far CCW or to MIN (this sets the scan rate of the cavity to max). Set the coarse centering knob to midway. As proper alignment is reached, you will see that less gain is needed to detect the pulses. Turn the laser power down to decrease detector and amplifier saturation.
14. Mode spectra: At this point it is beneficial to familiarize oneself with the cavity mode structure. Please refer to section 2.1.5 in the SuperCavity instruction manual, which discusses "Frequency Calibration of SuperCavity". Since the cavity used here is an SR-260, i.e. mirror spacing is 20 microns, then the Fractional Mode Splitting is about 0.0036. This suggests that all the modes are highly localized in the frequency domain (horizontal sweep on the scope). Also, note that the mode of interest is the  $TEM_{00}$  mode, the first in the mode structure series.

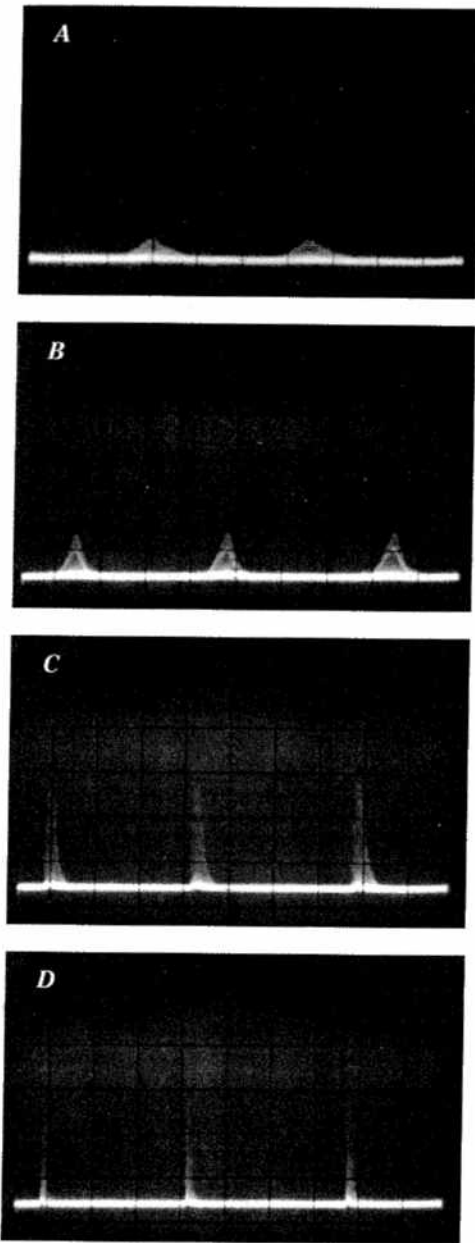

Fig. 11 – Photo sequence showing the shape of mode clusters as alignment is improved by iterating on the x, y and angle adjustments of the mount. A: misaligned, D: close to optimum alignment.

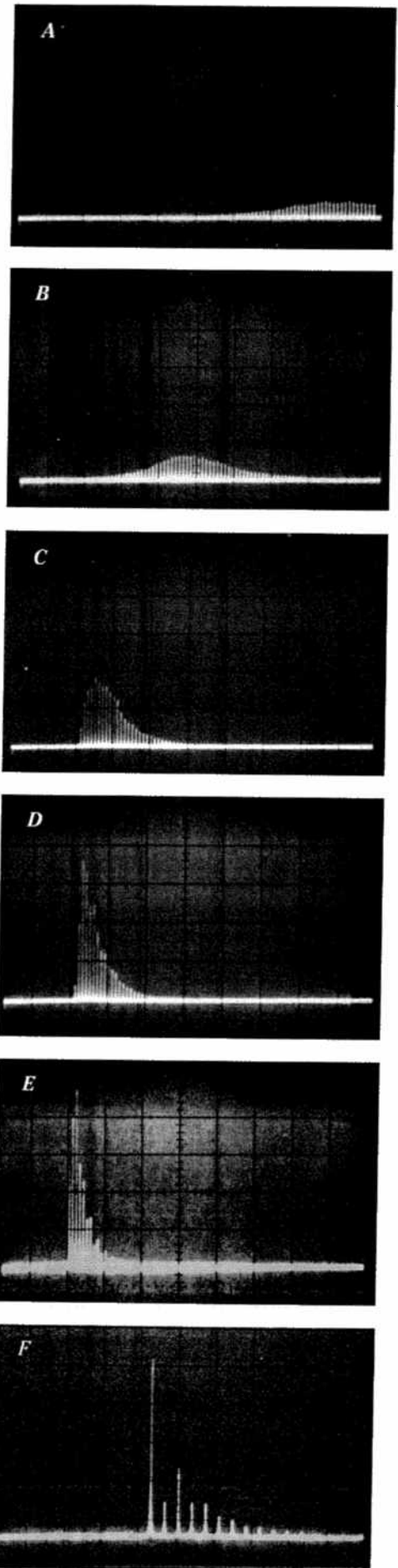

Fig. 12 – Same as Fig. 11 but with a different SWEEP setting.

15. Fine adjustment: Make sure the beam is entering the front aperture of the cavity. Without adjusting the angle controls of the LP-1 mount, translate the cavity in x and y by using the x and y knobs. Only slight adjustments of the x or y are necessary to enable seeing mode structure on the scope, as shown in Figs. 11a and 12a. If no pulses are detected then repeat the instructions starting at step #4 above.
16. Figures: Figures 11 and 12 are identical with the exception that in Figure 11 the SWEEP COARSE WIDTH is set to max CCW while in Fig. 12 it is set to midway. Adjust the centering knob as necessary.
17. Alignment sensitivities: The alignment of Series 200 SuperCavities is more sensitive to x and y as opposed to angle. Hence, all the adjustments at this point in the alignment are in the x and y control knobs of the LP-1 mount. On the other hand, Series 100 cavities exhibit the opposite behavior.
18. Final alignment: Once the mode clusters (Fig. 11a) are visible, it is straight forward to optimize the alignment by adjusting the x, y and angle knobs on the LP-1 mount. Note how the envelope grows in amplitude as it moves by adjusting the x, y and angle knobs on the LP-1 mount to the left (see Fig. 13). That is because the coupling efficiencies into lower order transverse modes improves causing these modes to grow in amplitude while higher order nodes diminish.

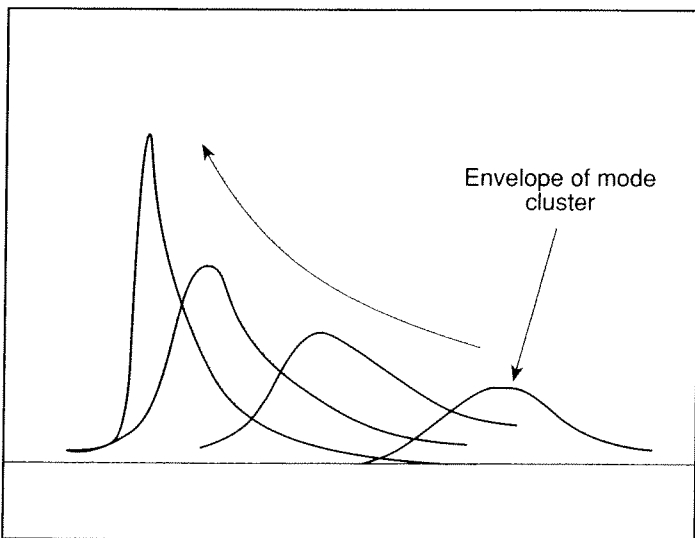

Fig. 13. – Motion of the mode cluster envelope as alignment is improved. The mode of interest is the first pulse on the left hand side of the mode cluster.

Iterate on the adjustment of the x and y axes of the LP-1 until the mode cluster amplitude is maximum, e.g. x-y-x-y-x ...etc. Fine tune the alignment by iterating on all four knobs of the LP-1 mount, i.e. angle as well as x-y.

The sequence of shots Figs. 11a to 11d is a representative of what you would see as alignment is optimized by adjusting the x and y knobs on the LP-1.

Final alignment is achieved when the first mode from the left side (the fundamental  $TEM_{00}$  cavity mode) reaches its maximum amplitude. This also minimizes the amplitudes of all the other modes. Expand the mode cluster on the scope by adjusting the CENTERING and WIDTH knobs.

It is possible to obtain an alignment such that the sum of all transverse modes is less than 5% in amplitude as compared to the fundamental mode (first mode on the left).

Reduce the laser power to an appropriate level by turning the right hand knob CCW. This reduces detector and amplifier saturation.

#### Discussion:

19. Figures 12a to 12f focuses the attention to one family of modes by adjusting the sweep and centering knobs on the controller. Scope gain setting is on 0.5 V/div and SR-UCC gain setting is on position #4 (High), with the exception of Fig. 12f on position #3.
20. Figure 12f shows the effect of the ellipticity of the laser beam. Note the alternating amplitudes of the transverse modes. You can also adjust the cavity alignment such that odd modes are about -20 dB below the fundamental (first) mode. The even modes will remain at -3 to -10 dB. A better mode structure may be obtained by using a pinhole (or a single-mode fiber) to spatially clean the beam.
21. Feel free to change the axial position of the coupling lens or to change the lens to different focal lengths. The coupling efficiency into the fundamental ( $TEM_{00}$ ) mode will change depending on mode matching between the input beam and the cavity mode.
22. SR-260 SuperCavity is designed with 30cm radius of curvature mirrors and separated 20 microns apart. The diameter and location of the  $TEM_{00}$  waist for the cavity is about 54 microns and 2 cm from the front surface of the cavity, respectively. The Rayleigh range for this cavity configuration is 1.73 mm. Therefore, for proper mode matching to SuperCavity, the coupling lens must focus the input beam to a spot of diameter = 54 microns and located on axis and  $20 \pm 1.73$  mm from front face of the cavity.
23. Series 100 cavities are 1" long. Therefore, the Rayleigh range there is 60.4 mm long and the waist location is roughly 30mm from the front face of cavity.
24. It might be beneficial to examine the mode structure of the light exiting the cavity. This can be done by removing the detector from the back of the cavity and using an IR (1.3 micron) viewing scope or camera. With the coarse sweep knob fully CCW, focus the camera at the back end of the cavity. You should see a small spot in the center of the window. It is very instructional to examine how the shape of this spot change as the cavity is misaligned either by x, y or angle. A tiny spot indicates that most of the energy is coupled into the  $_{00}$  mode. Misalignment shows the pattern changing to two spots, to a line, or to a rectangle. The change in shape is due to the superposition of all excited eigenmodes of the cavity, where each eigenmode has its own characteristic spatial energy distribution.

**Typical Operating Setups:**

Typical operation of the SuperCavity Optical Spectrum Analyzer includes connecting the SuperCavity to the controller, which in turn is connected to an oscilloscope, as shown schematically in Figs. 14 and 15. Figure 15 also shows three methods for coupling light into the fiber: by using an F-MA FiberMate- fiber coupler, by a single-mode fiber connector, or by a bare fiber coupler such as the Newport Model F-1015.

Note that it may be necessary for proper system operation to use an optical isolator such as the Newport Models ISO-7885, ISO-13FIB and ISO-15FIB. The degree of isolation needed depends upon the type of laser used. For most lasers, an acousto-optic-modulator or deflector or a 30dB isolator is sufficient to provide the necessary degree of optical isolation. However, some lasers, and in particular narrow linewidth laser diodes, may require more than 60dB of optical isolation for proper operation.

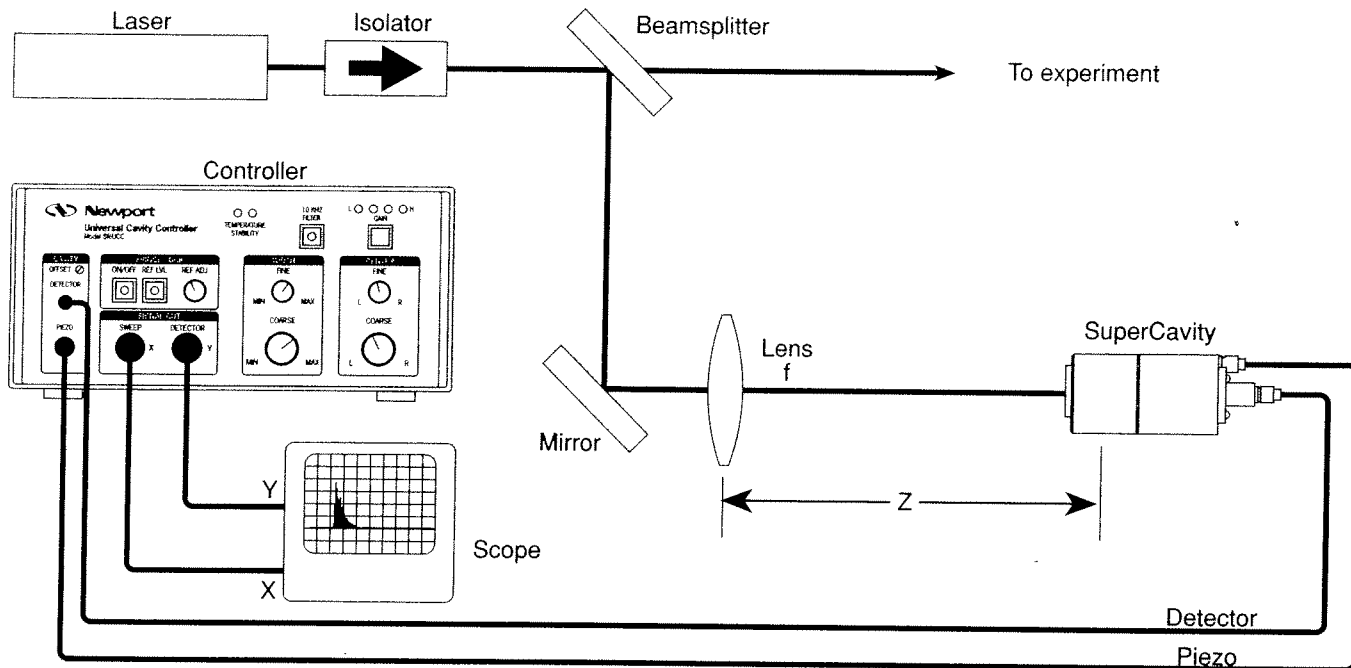
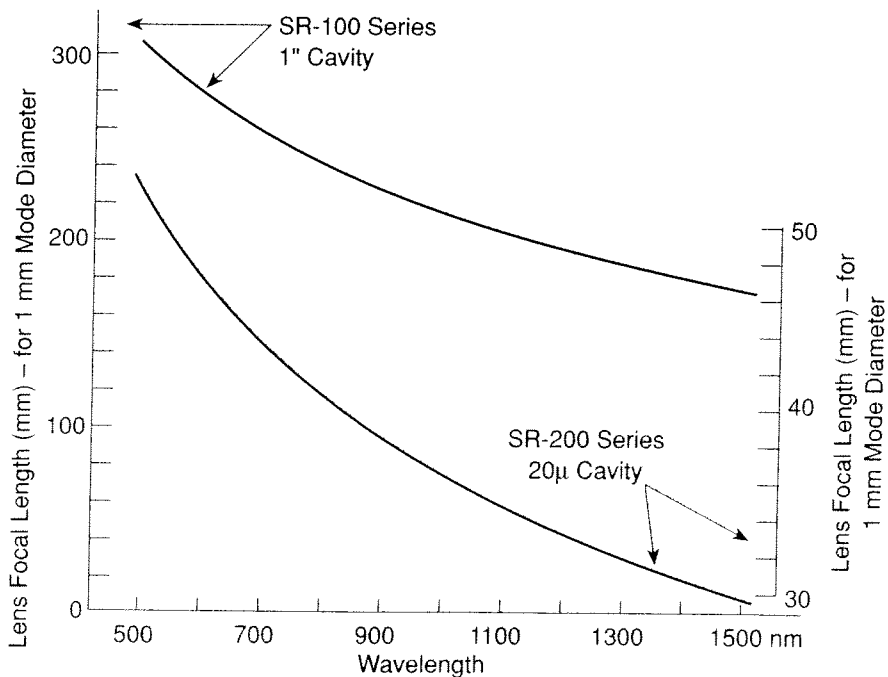
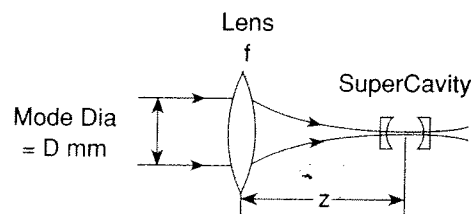

Fig 14a. – A representative lab setup. The focal length of the lens is selected by using Fig. 14b.



**Cavity Mode Matching:**



For mode diameter D mm, use focal length  $f_D$ :

$$f_D = D f_{(D-1)}$$

$f_{(D-1)}$  is lens focal length obtained from the chart on the left. Z is the distance from the lens to the beam waist.

Fig. 14b. – Cavity mode matching chart

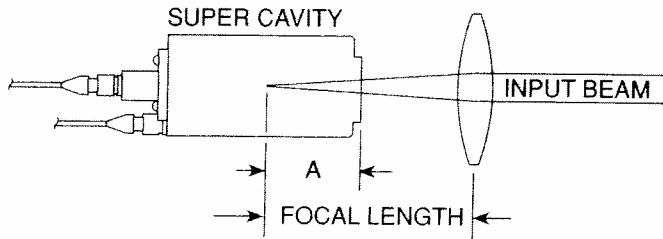

Series Model	Dimension A
SR-100	1.18" (3.0mm)
SR-200	0.87" (2.2cm)

Fig. 14c - Distance to focal waist inside cavity

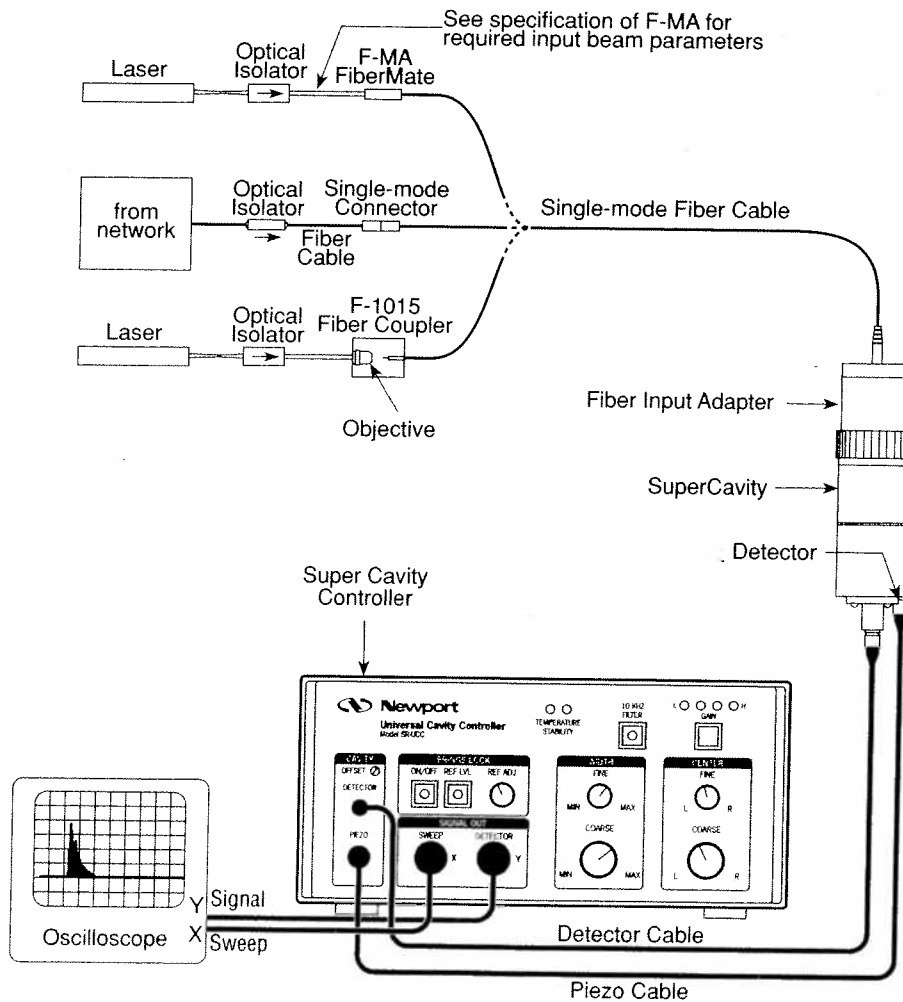

Fig. 15 - SuperCavity Fiber Input Adapter System. Schematic for a typical setup showing the different schemes for coupling light into the single-mode fiber. For proper SuperCavity system operation an optical isolator is necessary.

DS-05912 (Rev 10-91)

**U.S. Headquarters:**  
Newport Corporation  
P.O. Box 8020 / 18235 Mt. Baldy Circle  
Fountain Valley, CA 92728-8020  
Telephone: 714-963-9811  
Facsimile: 714-963-2015

**European Headquarters:**  
Federal Republic of Germany  
Newport GmbH  
Telephone: 06151-1540  
Facsimile: 06151-15450  
**United Kingdom:**  
Newport Ltd  
Telephone: 0582-769995  
Facsimile: 0582-762655

**Switzerland:**  
Newport Instruments AG  
Telephone: 01-740-2283  
Facsimile: 01-740-2503  
**Netherlands:**  
Newport B.V.  
Telephone: 03402-50588  
Facsimile: 03402-50577

**Canada:**  
Newport Instruments Canada  
Telephone: 416-567-0390  
Facsimile: 416-567-0392  
**Japan:**  
K. K. Newport  
Telephone: 06-359-0270  
Facsimile: 06-359-0280

